

Series 150 AFCO-Rail Glass Rail











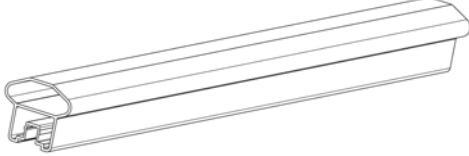

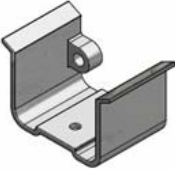

INSTALLATION INSTRUCTIONS



AFCO
Columns and Railings
a Division of AFCO Industries, Inc.

PARTS INCLUDED:

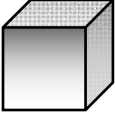
GLASS RAIL—TOP RAIL (1)		GLASS RAIL— BOTTOM RAIL (1)	
A 		B 	
SADDLE BRACKET (2)	BRACKET COVER (2)	BOTTOM BRACKET (2)	10" SUPPORT BLOCK (1)
C 	D 	E 	F 
SUPPORT BLOCK CONNECTOR (2)	#10x1" SELF DRILLING SCREW (12)	3 1/2" DRIVER BIT (1)	ADHESIVE TAB SHEET (1)
G 	H 	I 	J 
PAINTED RAIL INSERT (4)	RUBBER GASKET (2)	#10x1-12" SELF DRILLING SCREW (4)	2" X 2" FOAM BLOCK SPACER (2)
K 	L 	M 	N 

150 SERIES AFCO-RAIL LEVEL RAIL

TOOLS REQUIRED:

Drill bit 5/32" (.156")
Drill (with adjustable clutch, recommended)
Miter Saw (with metal cutting blade)
Level
Rubber mallet
Tape measure
Touch-up paint

NOTES:

- **NOTE: Recommended to have 2 people to install glass rail for safer installation.**
- Posts packaged separately.
- An Optional AFCO-Tool is available to simplify the locating, pre-drilling and installation of brackets.

FOR A SUCCESSFUL INSTALLATION:

- Read the instructions completely before beginning the installation.
- Plan your railing project. Sketch your project with the actual measurements of your deck or balcony complete with post locations.
- Check local building codes to ensure compliance.
- Check carton(s) to determine part count is complete.
- After cutting rails, balusters, or posts, paint exposed metal for maximum protection against the elements.
- Installation is best accomplished with two people.
- Wear personal protection equipment; safety glasses, etc.
- Use care not to over-torque the screws. Pre-drilling is recommended.
- **Provided hardware to install AFCO-Rail is for use with Aluminum AFCO-Rail posts. If installing to other surfaces the installer must acquire the appropriate hardware as needed for proper installation.**

POSTS INSTALLATION:

1. Measure and locate the position of the post(s) based on the project layout.
2. Install the post by attaching the aluminum mounting flange to the surface of the deck or balcony. Position the post so the fastener will go into the floor joist, and make sure the decking is firmly attached to the joist at the location of the post. If necessary, use wood blocking as reinforcement underneath the decking where the posts are located. Post mounting fasteners should be able to secure into the joist or reinforcement braces, not just the decking itself. When installing AFKO-Rail Post on top of a wood surface, screws must be lagged into at least 3" of solid wood. Deck boards sized 5/4" or 1-1/2" do not provide sufficient material for a safe installation.

Note: When installing AFKO-Rail Post onto treated wood surface, install the provided ACO pad (included in the post kit) between the post base and the treated surface.

3. Position the post to the deck surface. Four 3/8" diameter mounting holes are provided on the mounting flange. Mark the mounting flange hole locations and remove the post. Pre-drill the marked locations into the decking and reinforcement for the appropriate fasteners. Remount the post. Insert the appropriate fasteners to secure the mounting flange to the deck structure.

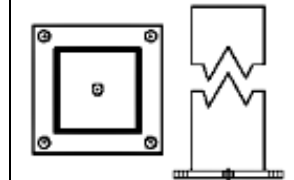

4. Finish by sliding the base trim to the bottom of the post to cover the mounting flange.

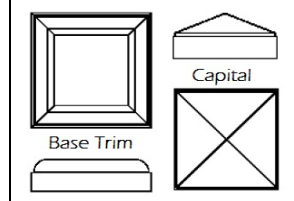

5. To install the post cap, set post capital in place on top of the post and tap lightly with a rubber mallet to drive the post cap onto the post. Silicone or water based caulking may be used to secure the post cap and base trim. *(Note: Cap installation step is typically completed after all rails have been installed.)*

LEVEL RAIL INSTALLATION:

1. Measure the opening between the installed posts. If required to cut rail shorter than provided, start with the Bottom Rail (B), and mark the rail to the same distance measured between posts. Carefully cut the rail to the required length. Now mark the Top Rail (A) 3/4" shorter than the bottom rail and cut to length. *(The top rail is cut 3/4" shorter than the bottom rail for bracket clearance)*

Note: Prior to cutting rail ensure the space between glass infill and the post will be no greater than 4". Subtract length of glass infill from the distance measured between posts and divide by 2. * Use the below table to help determine the cut size required for the glass infill. *****

***** GLASS INFILL USED MUST BE 1/4" THICK TEMPERED GLASS OR EQUIVALENT *****

Rail Width Between Posts	36" Height Rail	42" Height Rail	Rail Width Between Posts	36" Height Rail	42" Height Rail	Rail Width Between Posts	36" Height Rail	42" Height Rail
	Glass Size (in)	Glass Size (in)		Glass Size (in)	Glass Size (in)		Glass Size (in)	Glass Size (in)
72"	64.5" x 31.5"	64.5" x 37.5"	59"	51.5" x 31.5"	51.5" x 37.5"	46"	38.5" x 31.5"	38.5" x 37.5"
71"	63.5" x 31.5"	63.5" x 37.5"	58"	50.5" x 31.5"	50.5" x 37.5"	45"	37.5" x 31.5"	37.5" x 37.5"
70"	62.5" x 31.5"	62.5" x 37.5"	57"	49.5" x 31.5"	49.5" x 37.5"	44"	36.5" x 31.5"	36.5" x 37.5"
69"	61.5" x 31.5"	61.5" x 37.5"	56"	48.5" x 31.5"	48.5" x 37.5"	43"	35.5" x 31.5"	35.5" x 37.5"
68"	60.5" x 31.5"	60.5" x 37.5"	55"	47.5" x 31.5"	47.5" x 37.5"	42"	34.5" x 31.5"	34.5" x 37.5"
67"	59.5" x 31.5"	59.5" x 37.5"	54"	46.5" x 31.5"	46.5" x 37.5"	41"	33.5" x 31.5"	33.5" x 37.5"
66"	58.5" x 31.5"	58.5" x 37.5"	53"	45.5" x 31.5"	45.5" x 37.5"	40"	32.5" x 31.5"	32.5" x 37.5"
65"	57.5" x 31.5"	57.5" x 37.5"	52"	44.5" x 31.5"	44.5" x 37.5"	39"	31.5" x 31.5"	31.5" x 37.5"
64"	56.5" x 31.5"	56.5" x 37.5"	51"	43.5" x 31.5"	43.5" x 37.5"	38"	30.5" x 31.5"	30.5" x 37.5"
63"	55.5" x 31.5"	55.5" x 37.5"	50"	42.5" x 31.5"	42.5" x 37.5"	37"	29.5" x 31.5"	29.5" x 37.5"
62"	54.5" x 31.5"	54.5" x 37.5"	49"	41.5" x 31.5"	41.5" x 37.5"	36"	28.5" x 31.5"	28.5" x 37.5"
61"	53.5" x 31.5"	53.5" x 37.5"	48"	40.5" x 31.5"	40.5" x 37.5"			
60"	52.5" x 31.5"	52.5" x 37.5"	47"	39.5" x 31.5"	39.5" x 37.5"			

2. Install Support Block Connectors (G) using #10x1" self drilling screw (H) to the flat underside of Bottom Rail (B).



Note: One Support Block, cut from Support Block Material (F), is recommended for rails measuring 72" in length or less. Install the Support Block Connector (G) at center point of Bottom Rail (B) on the flat non-slotted side. If two or more Support Blocks are used, install Support Block Connectors (G) equally distributed from each end of the Bottom Rail (B).

3. Cut 10" Support Block (F) to required length and press over the Support Block Connector installed in step 2. Support block is typically cut at 2", but can be cut longer based on your project needs.

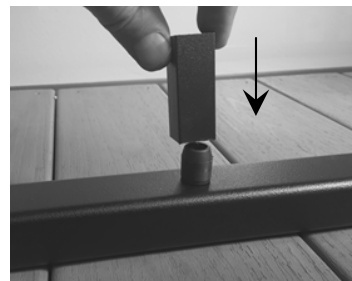

(Note: all cut dimensions in this instruction is based on 2" space under the bottom rail and 36" height top rail. Any variation from this will require additional measuring and planning for bracket placement.)

4. Confirm the length of the glass infill being installed and subtract that dimension from the length of the bottom rail cut in step 1, divide that difference by 2. This will be the length of the required insert. Locate the painted Glass Rail Insert (K) and cut (if required) 4 pc provided to the calculated dimension, these will be used for the bottom rail, and top rail.



Note: Inserts are pre-cut to allow a 3 - 3/4" space between post and glass infill.

5. Slide one cut to length glass rail insert (K) into each end of the Bottom Rail (B) until flush with each end of the rail. Place Bottom Brackets (E) on end of each rail with counter-bore holes down and facing outward and away from the post.

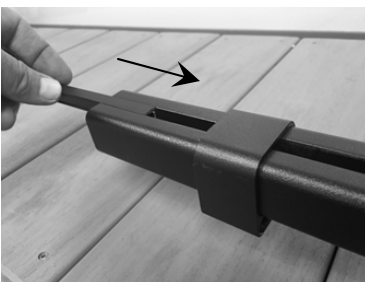

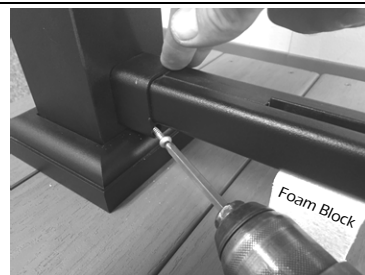

6. Place Bottom Rail (B) between posts ensuring rail is level and support block is properly installed and grooved side of rail is facing upward. Place provided 2" Foam Blocks Spacers (N) under each end of the Bottom Rail to help level it and aid in the installation. Slide Bottom Brackets (E) firmly against and centered on the post and secure with 2ea, required #10 x 1" self drilling screws (H).

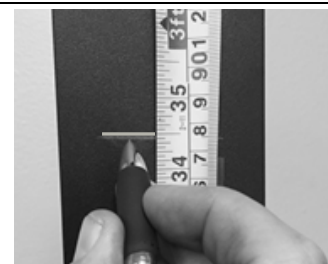

An AFCO Tool (not shown) will help to locate the brackets in this step. (Once fastener location is determined, pre-drilling is recommended.)

7. Measure up 34-1/2" (36" rail height) from the floor and mark a level, horizontal line on the side of the post the Saddle Bracket (C) will be mounted. Align the screw holes in the Saddle Bracket with the horizontal line marked on the post making sure the bracket is centered on the post, and attach Saddle Brackets with #10 x 1" self drilling screws (H). * **Note: Measure up 40 - 1/2" for 42" height rail.** *
(An AFCO Tool will help with locating the brackets in this step) (Pre-drilling is recommended.)

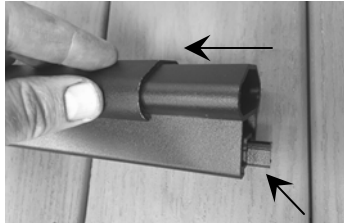

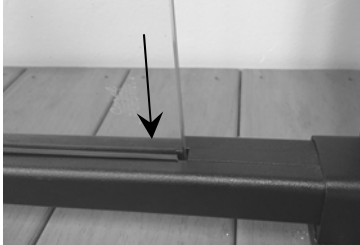
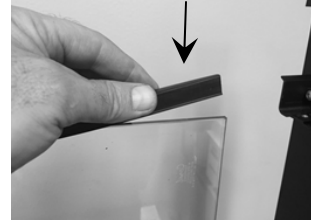
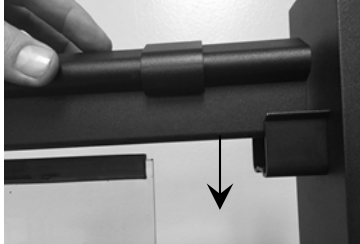
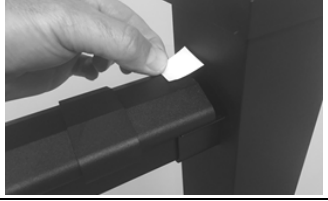
<p>8. Slide the Bracket Covers (D) on the Top Rail (A) approximately 3 - 4 inches inward on each end of the top rail and install the remaining 2 glass rail inserts (K) into each end of the top rail until they are protruding approximately 3/8" from the end of the top rail.</p>	
<p>9. Trim the 2 pieces of Rubber Gasket (L) material the same length as the glass infill being installed. Install one piece on the bottom edge of the glass infill. <i>(It is recommended to have 2 people at this point to complete installation safely)</i></p>	
<p>10. With help from another person, lift the glass infill and place the bottom of the glass panel with rubber gasket (L) into the groove of the bottom rail (B) and gently press downward starting from one end until the glass fully seats in place, into the entire length of the bottom rail. <i>NOTE: (Wiping the gasket with a light soapy rag will aid in the glass panel assembly)</i></p>	
<p>11. While holding the glass infill upright have an assistant place the 2nd piece of the rubber gasket material (L) on the top edge of the glass infill panel.</p>	
<p>12. While holding glass infill plumb, place Top Rail (A) over the glass so that it is centered into the groove of the Top Rail. Press down lightly until the glass seats into the groove of the Top Rail and is fully seated in the Saddle Brackets mounted on the posts. Inserts may require to be slid out towards the post in top rail approximately 3/8" in order to fit the glass infill in place. <i>NOTE: (Wiping the gasket with a light soapy rag will aid in the glass panel assembly)</i></p>	
<p>13. Apply Adhesive Tab (J) to the flat, top surface of both ends of the Top Rail (A), near the post. Slide Bracket Cover (D) to interlock with flange on the Saddle Bracket (C).</p>	
<p>14. Install #10x1-1/2" Self Drilling Screws (M) into the Top Rail (A) from the underside of each Saddle Bracket (C) through the provided locating hole to securely fasten to the rail through the insert to properly secure railing system. <i>(Pre-drilling is recommended through the insert and the interior wall of the Top Rail (A) only)</i></p>	